

CR-250

CITYRANGE CRANE

SPECIFICATION

CRANE SPECIFICATION

Performance

Maximum rated lifting capacity:	25 metric tons × 2.8m
Boom length:	6.7m – 28.0m (6 section)
Fly jib length:	5.4m – 8.2m (2 section, optional)
Boom derricking angle:	-10.5° – 81°
* Boom derricking time:	33sec. (0° – 81°)
* Boom extending time:	68sec. (6.7m – 28.0m)
* Hoisting line speed	
Main winch:	104m/min. (at 4th layer)
Auxiliary winch:	93m/min. (at 2nd layer)
* Hoisting hook speed	
Main winch (parts of line; 7):	
14.9m/min. (at 4th layer)	
Auxiliary winch (parts of line; 1):	
93m/min. (at 2nd layer)	
* Slewing speed:	2.6rpm
(* Speed:	Subject to no load)

Hoisting Ropes

Main winch;	
Diameter:	14mm
Length:	160m
Auxiliary winch;	
Diameter:	14mm
Length:	80m

Hydraulic System

Oil pump:	4 pumps, plunger and gear type
Hoisting motor:	Axial plunger type
Slewing motor:	Axial plunger type
Cylinder:	Double acting type
Control valve:	Double acting with integral check and relief valves
Oil reservoir capacity:	440 lit.

Winch System

Main winch & Auxiliary winch:	Driven by axial plunger type hoisting motor with gear reduction. Controlled independently by respective operating lever. Equipped with automatic brake.
-------------------------------	---

Safety devices

ACS (Automatic Crane Stopper, with Voice alarm)
 Boom falling prevention device
 Overhoist prevention device
 Drum lock device (on aux. winch)
 Automatic winch brake
 Irregular winding prevention device
 Hydraulic safety valve
 Outrigger lock device

Option

Fly jib
 Hook for 25 ton
 Amplifier

CARRIER SPECIFICATION

General dimensions & G.V.W.

Overall length:	approx. 9,065mm
Overall width:	approx. 2,395mm
Overall height:	approx. 3,400mm
	3,360mm
	(With spring lock cylinders fully retracted)
Wheel base:	3,500mm
Treads; Front & Rear:	1,965mm
Center to center of extended outriggers:	6,000mm (Fully extended)
Gross vehicle weight:	approx. 24,000kg
Front & Rear:	approx. 12,000kg

Carrier

Drive system:	4 × 2 / 4 × 4
Maximum traveling speed:	49km/h
Gradeability (tanθ):	60% (computed @G.V.W. = 24,000kg)
Minimum turning radius:	5.0m (4 wheel steer)
(center of extreme outer tire):	8.3m (2 wheel steer)
Engine:	
Maker:	Mitsubishi
Model:	6D16-TE1 (Turbo-charged)
Type:	4 cycle, water cooled, direct injection diesel engine
No. of cylinder:	6
Piston displacement:	7,545cc
Max.output horsepower:	158KW/2,800r.p.m.
Max.output torque:	696N-m/1,600r.p.m.
	NOTE: The engine complies with Draft Directive (10201/96) – 95/0209 (COD); (Stage I limit).
Torque converter:	Engine mounted 3 elements 1 stage (with lock up clutch)
Transmission:	Remote mounted full automatic with transfer gear box 4 forward & 2 reverse speed (with Hi-Low selector)
Axle; Front & Rear:	Planetary, drive/steer type
Suspension; Front & Rear:	Coil spring equipped with hydraulic shock absorber and hydraulic locking device
Steering:	Full hydraulic power steering with reverse steering correction mechanism Five steering modes available (with automatic rear wheel steering lock system)
	1. Front wheel steer
	2. 4-wheel coordinated steer
	3. 4-wheel crab steer
	4. Rear wheel steer
	5. Independent front and rear steer
Brake; Service brake:	Air-over hydraulic disk brake on 4 wheels (2 circuit) Equipped with service brake lock
Parking brake:	Spring applied, electrically air released parking brake mounted on front axle, internal expanding type
Auxiliary brake:	Exhaust brake
Electric system:	24V
Alternator:	24V – 40A
Battery:	12V – 115F51 × 2
Fuel tank capacity:	300 lit.
Driver's cab:	All steel welded construction, 1 person, Air-conditioned
Tire size; Front & Rear:	385/95R25 170E ROAD
Safety devices:	Emergency steering device Brake fluid leak warning device Suspension lock device Service brake lock Engine overrun alarm Over-shift prevention device Radiator coolant leakage warning device Motor driven retractable side mirrors

■ RATED LIFTING CAPACITY (1)

Based on *BS 1757 : 1986 *DIN 15019-2 *75% of tipping loads

Working radius (m)	Outriggers fully extended (6.0m) - 360° full range					Outriggers intermediately extended (4.5m) - 360° full range					Outriggers completely retracted (blocked on vertical cylinders) - 360° full range				
	6.7m Boom	11.0m Boom	15.2m Boom	21.6m Boom	28.0m Boom	6.7m Boom	11.0m Boom	15.2m Boom	21.6m Boom	28.0m Boom	6.7m Boom	11.0m Boom	15.2m Boom	21.6m Boom	28.0m Boom
2.8	25.00	12.00	12.00			25.00	12.00	12.00			10.00	9.50	7.90		
3.0	22.00	12.00	12.00	8.00		22.00	12.00	12.00	8.00		8.75	8.45	7.15	6.50	
3.5	20.00	12.00	12.00	8.00		20.00	12.00	12.00	8.00		6.60	6.30	5.65	5.45	
4.0	17.00	12.00	12.00	8.00	6.50	17.00	12.00	12.00	8.00	6.50	5.10	4.85	4.55	4.55	4.25
4.5	15.00	12.00	12.00	8.00	6.50	15.00	12.00	12.00	8.00	6.50	4.10	3.85	3.70	3.80	3.65
5.0		12.00	12.00	8.00	6.50		12.00	12.00	8.00	6.50		3.10	3.00	3.20	3.15
5.5		12.00	12.00	8.00	6.50		9.80	9.70	8.00	6.50		2.50	2.40	2.70	2.70
6.0		12.00	11.50	8.00	6.50		8.20	8.10	8.00	6.50		2.05	1.95	2.30	2.35
6.5		11.30	10.60	8.00	6.50		7.00	6.85	7.25	6.50		1.60	1.55	1.95	2.00
7.0		10.15	9.90	7.85	6.50		6.00	5.90	6.55	6.50		1.25	1.20	1.65	1.75
8.0		7.90	7.80	7.10	5.90		4.60	4.50	5.10	5.40		0.70	0.60	1.15	1.30
9.0		6.20	6.10	6.35	5.35		3.60	3.45	4.05	4.40					
10.0			4.90	5.45	4.80			2.65	3.30	3.60					
11.0			4.00	4.60	4.30			2.05	2.65	3.00					
12.0			3.25	3.85	3.85			1.55	2.15	2.50					
13.0			2.65	3.30	3.50			1.15	1.75	2.10					
14.0				2.80	3.10				1.40	1.75					
15.0				2.35	2.70				1.15	1.45					
16.0				2.00	2.35				0.90	1.20					
17.0				1.70	2.00				0.70	0.95					
18.0				1.45	1.75				0.50	0.80					
19.0				1.20	1.50				0.35	0.60					
20.0			[19.7m]	1.05	1.30					0.45					
21.0					1.15					0.35					
22.0					0.95										
23.0					0.80										
24.0					0.70										
25.0					0.60										
26.0					0.50										
Standard hook	for 25 ton (optional)	for 22 ton				for 25 ton (optional)	for 22 ton				for 25 ton (optional)	for 22 ton			
Hook mass	200 kg	200 kg				200 kg	200 kg				200 kg	200 kg			
Parts of line	7	4				7	4				7	4			
Critical boom angle	—	—	—	—	—	—	—	—	—	35°	—	20°	51°	62°	69°

(Unit : Metric ton)

■ RATED LIFTING CAPACITY (2)

28.0m Boom + 5.4m Jib (Standard hook for 4.0ton. Hook mass 60kg)													
Outriggers fully extended (6.0m) - 360° full range							Outriggers intermediately extended (4.5m) - 360° full range						
Boom angle (°)	Offset 5°		Offset 25°		Offset 45°		Boom angle (°)	Offset 5°		Offset 25°		Offset 45°	
	Working radius (m)	Load (t)	Working radius (m)	Load (t)	Working radius (m)	Load (t)		Working radius (m)	Load (t)	Working radius (m)	Load (t)	Working radius (m)	Load (t)
81.0	5.2	3.00	7.0	2.50	8.3	1.55	81.0	5.2	3.00	7.0	2.50	8.3	1.55
77.7	7.2	3.00	8.9	2.50	10.0	1.55	77.7	7.2	3.00	8.9	2.50	10.0	1.55
75.0	8.9	3.00	10.4	2.30	11.4	1.50	75.0	8.9	3.00	10.4	2.30	11.4	1.50
73.0	10.0	3.00	11.5	2.14	12.4	1.46	73.0	10.0	3.00	11.5	2.14	12.4	1.46
70.0	11.7	2.60	13.1	1.94	13.9	1.42	70.0	11.7	2.60	13.1	1.94	13.9	1.42
65.0	14.3	2.15	15.7	1.69	16.3	1.35	69.0	12.2	2.50	13.6	1.88	14.4	1.40
60.0	16.8	1.83	18.1	1.49	18.7	1.30	67.0	13.2	2.14	14.7	1.77	15.3	1.37
55.0	19.2	1.55	20.3	1.35	20.8	1.25	64.0	14.7	1.63	16.0	1.46	16.8	1.33
54.0	19.6	1.45	20.7	1.32	21.2	1.22	60.0	16.6	1.14	17.9	1.02	18.5	1.00
52.0	20.4	1.29	21.5	1.19	22.0	1.18	55.0	18.9	0.70	19.9	0.67	20.7	0.60
50.0	21.2	1.14	22.3	1.05	22.7	1.08	50.0	21.0	0.39	21.9	0.37		
48.0	22.0	1.01	23.0	0.94	23.3	0.99	Critical boom angle	48°		48°		53°	
45.0	23.2	0.82	24.1	0.77									
40.0	25.0	0.58	25.8	0.54									
35.0	26.6	0.40	27.2	0.38									
Critical boom angle	33°		33°		46°								

(Unit : Metric ton)

28.0m Boom + 8.2m Jib (Standard hook for 4.0ton. Hook mass 60kg)													
Outriggers fully extended (6.0m) - 360° full range							Outriggers intermediately extended (4.5m) - 360° full range						
Boom angle (°)	Offset 5°		Offset 25°		Offset 45°		Boom angle (°)	Offset 5°		Offset 25°		Offset 45°	
	Working radius (m)	Load (t)	Working radius (m)	Load (t)	Working radius (m)	Load (t)		Working radius (m)	Load (t)	Working radius (m)	Load (t)	Working radius (m)	Load (t)
81.0	6.0	2.00	8.7	1.20	10.5	0.80	81.0	6.0	2.00	8.7	1.20	10.5	0.80
77.0	8.7	2.00	11.1	1.20	12.7	0.80	77.0	8.7	2.00	11.1	1.20	12.7	0.80
75.0	10.0	2.00	12.2	1.20	13.7	0.78	75.0	10.0	2.00	12.2	1.20	13.7	0.78
72.0	11.9	1.81	14.0	1.20	15.3	0.75	72.0	11.9	1.81	14.0	1.20	15.3	0.75
70.0	13.0	1.71	15.1	1.18	16.4	0.74	70.0	13.0	1.71	15.1	1.18	16.4	0.74
65.0	15.9	1.49	17.8	1.12	18.9	0.72	65.0	15.9	1.49	17.8	1.12	18.9	0.72
60.0	18.6	1.33	20.3	1.05	21.3	0.69	63.0	16.9	1.26	18.8	1.09	19.8	0.70
55.0	21.2	1.20	22.7	0.98	23.5	0.67	60.0	18.4	0.98	20.2	0.87	21.3	0.69
53.0	22.1	1.14	23.6	0.95	24.3	0.66	58.0	19.4	0.81	21.2	0.72	22.2	0.68
50.0	23.5	0.96	24.9	0.77	25.4	0.65	55.0	20.8	0.60	22.5	0.54	23.3	0.53
47.0	24.7	0.80	26.1	0.63	26.5	0.64	50.0	23.1	0.31				
45.0	25.6	0.69	26.8	0.56			Critical boom angle	48°		53°		53°	
40.0	27.5	0.49	28.5	0.39									
35.0	29.1	0.33											
Critical boom angle	33°		38°		45°								

(Unit : Metric ton)

■ RATED LIFTING CAPACITY (3)

Working radius (m)	Stationary on rubber (without outriggers)					
	6.7m Boom		11.0m Boom		15.2m Boom	
	Over front	360° full range	Over front	360° full range	Over front	360° full range
3.0		6.00		5.50		5.20
3.5	8.50	4.50	8.50	4.10	8.00	3.80
4.0	8.50	3.30	8.50	3.20	8.00	3.00
4.5	7.50	2.55	7.20	2.55	6.50	2.40
5.0			6.10	2.00	5.40	1.90
5.5			5.10	1.55	4.55	1.50
6.0			4.25	1.20	3.85	1.15
6.5			3.55	0.90	3.30	0.85
7.0			3.00	0.65	2.80	
8.0			2.15		2.05	
9.0			1.55		1.50	
10.0					1.00	
11.0					0.60	
Standard hook	for 22 ton					
Hook mass	200 kg					
Parts of line	6		4			
Critical boom angle	—	—	—	30°	33°	57°

(Unit : Metric ton)

Working radius (m)	Pick & Carry (less than 2km/h) (without outriggers)					
	6.7m Boom		11.0m Boom		15.2m Boom	
	Over front	360° full range	Over front	360° full range	Over front	360° full range
3.0		4.80		4.40		4.00
3.5	6.80	3.60	6.40	3.30	5.90	3.00
4.0	6.80	2.65	6.40	2.55	5.90	2.40
4.5	6.00	2.05	5.50	2.05	5.00	1.90
5.0			4.75	1.50	4.30	1.40
5.5			4.10	1.05	3.65	1.00
6.0			3.40	0.65	3.10	0.60
6.5			2.85		2.65	
7.0			2.40		2.25	
8.0			1.65		1.60	
9.0			1.00		1.00	
10.0					0.50	
11.0						
Standard hook	for 22 ton					
Hook mass	200 kg					
Parts of line	6		4			
Critical boom angle	—	—	—	42°	35°	60°

(Unit : Metric ton)

Notes for the Rated Lifting Capacity Chart

■ Rated lifting capacity charts (1) and (2)

When outriggers are used.

1. The rated lifting capacity chart indicates the maximum load which can be lifted by this crane provided it is level and standing on firm, level ground. It includes the mass of the hook and all other slings etc.
The area of the rated lifting capacity chart surrounded by a bold line is the area in which capacity determined by the structural strength of the crane. Elsewhere the crane's stability is the deciding factor.
2. The working radius is based on the actual radius including boom deflection.
Always use the actual working radius as the standard criterion for crane operation.
3. The jib working radius is based on the jib mounted on the end of the 28.0m boom. If the boom is at any other length use the boom angle as the standard criterion for crane operation. (The jib is optional.)
4. Never operate the jib when the outriggers are fully retracted. (The jib is optional.)
5. The rated lifting capacity of the rooster sheave is the rated lifting capacity of the boom minus the mass of all attached slings etc. to the boom, with an upper limit of 4,000Kg.
{The hook for use with the rooster sheave is the 4.0 ton hook (mass 60kg) with one part of line.}
6. If the boom length exceeds the rated length use the rated lifting capacity for the rated length or for the next highest boom length step, whichever gives the smaller rated lifting capacity.
7. If you are working with the boom while the jib is rigged subtract 1,000kg from the rated lifting capacity as well as subtracting the mass of the slings etc. Do not use the rooster sheave in this situation. (The jib is optional.)
8. In whatever working conditions the corresponding boom critical angle is shown in the table. Lowering the boom below the critical angle could cause the machine to tip over even if the crane is not carrying any added load.
9. The standard parts of line for each boom length are as shown in the table. If you work with a non-standard number of parts of line take 3,800kg as the maximum load on any part of the wire rope.
10. The rated lifting capacity does not take the effects of wind into account.
Stop work immediately if the wind speed reacts 10m/s even briefly.
11. Kato bears no liability whatsoever for damage, crane tipping or other accident caused by crane operations which differ from the directions contained in the instruction manual and the warning labels.

■ Rated lifting capacity chart (3)

When outriggers are not used.

1. The rated lifting capacity chart indicates the maximum load which can be lifted by this crane provided it is standing on firm, level ground with all tyres inflated to the rated pressure and with the suspension lock cylinders fully retracted. It includes the mass of the hook and all other slings etc.
The area of the rated lifting capacity chart surrounded by a bold line is the area in which capacity is determined by the structural strength of the crane. Elsewhere the crane's stability is the deciding factor. (Rated tyre pressure: 9.0bar)
2. The rated lifting capacity differs between the front area capacity and the full range capacity. When slewing from the front to the side take care that the crane could not be overloaded.

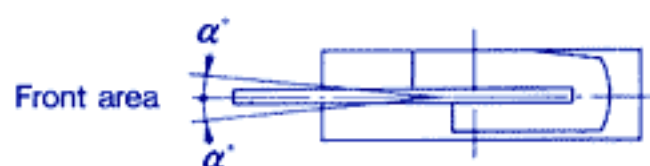

Crane operation	Stationary on rubber operation	Pick and carry operation
Area α°	1'	1'

3. Do not work with the jib or with a boom length of more than 15.2m. (The jib is optional.)
4. Always engage the parking brake before you start stationary on rubber operation.
5. For pick and carry operation the high/low speed switch must be switched to "ON" (low range) and the shift lever set to speed 1.
6. For pick and carry operation lower the load to just above the ground and keep your speed strictly less than 2km/h to avoid swinging the load.
Take particular care to avoid sharp cornering and sudden starts and stops.
7. Never operate the crane during pick and carry operation. The slewing brake must always be engaged.
8. Other than the above precautions observe points (2), (5), (6), (8), (9), (10) and (11) of the section "Precautions on outrigger use".

WORKING RANGE

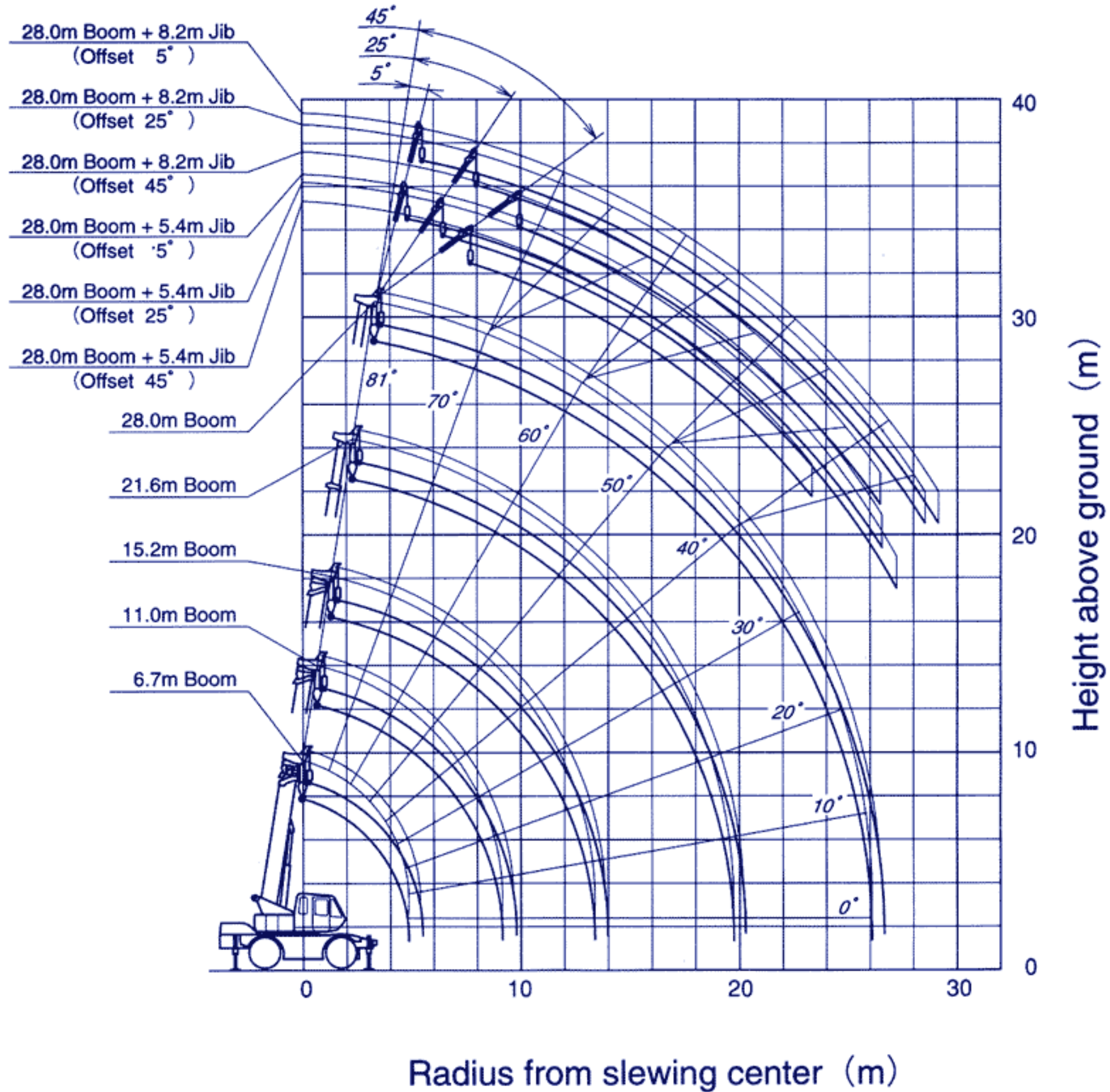

Note : This diagram does not include deflection of Boom and Fly Jib.

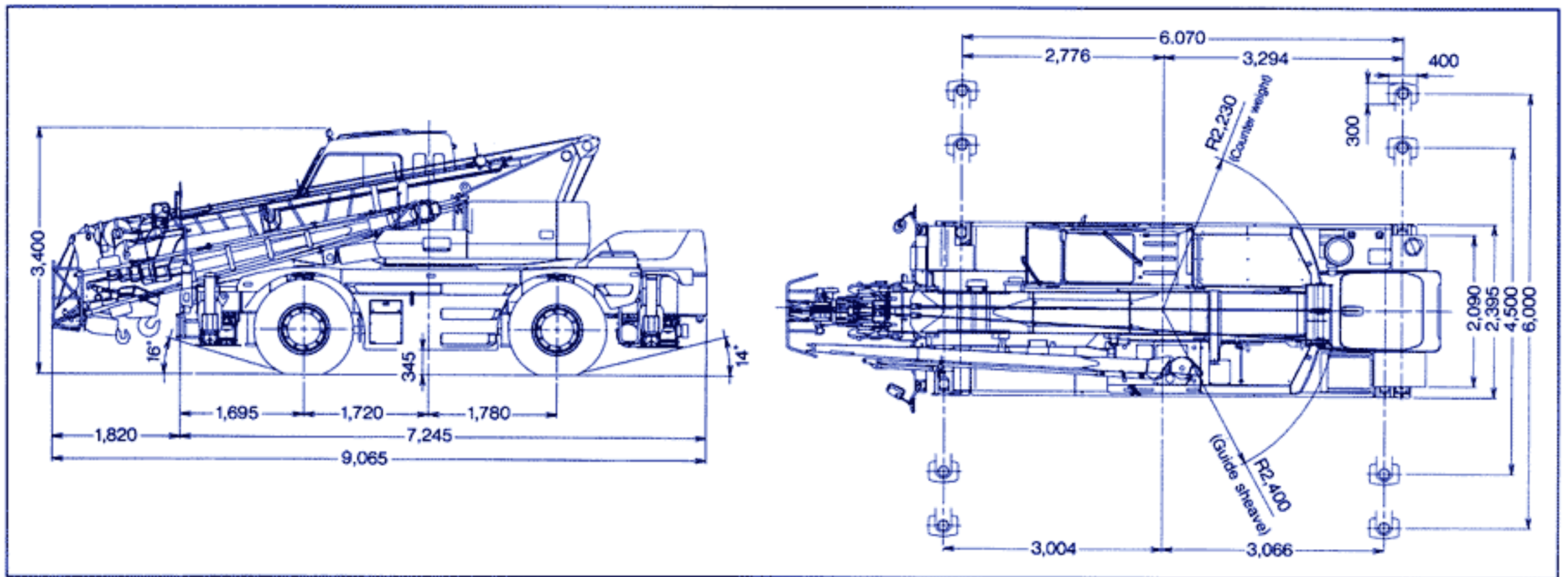

Minimum Road Width for Right-Angle Turn

Right turn in two-wheel steering mode

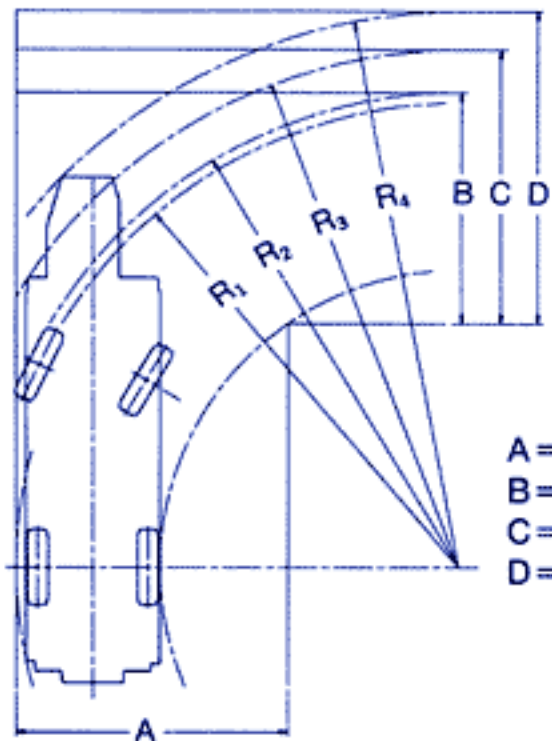

- $R_1 = 8.30\text{m}$
(Minimum turning radius)
- $R_2 = 8.49\text{m}$
(Turning radius of extremely outer tire)
- $R_3 = 9.25\text{m}$
(Chassis turning radius)
- $R_4 = 9.93\text{m}$
(Boom end turning radius)

- A = 4.85m (Width of entrance)
- B = 4.13m (Width of wheel exit)
- C = 4.89m (Width of chassis exit)
- D = 5.56m (Width of exit at end of boom)

Right turn in 4-wheel steering mode

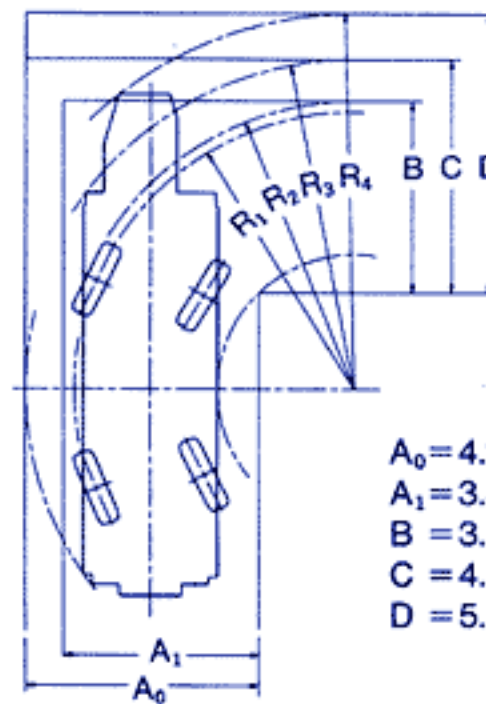

- $R_1 = 5.00\text{m}$
(Minimum turning radius)
- $R_2 = 5.19\text{m}$
(Turning radius of extremely outer tire)
- $R_3 = 5.95\text{m}$
(Chassis turning radius)
- $R_4 = 6.77\text{m}$
(Boom end turning radius)

- $A_0 = 4.16\text{m}$ (Width of entrance)
- $A_1 = 3.48\text{m}$ (Width of wheel entrance)
- B = 3.44m (Width of wheel exit)
- C = 4.20m (Width of chassis exit)
- D = 5.02m (Width of exit at end of boom)

Note: The above values are based on calculations.

